

# Site Inventory Form

State Historical Society of Iowa

(November 2005)

State Inventory No. 92-00588

New  Supplemental

Part of a district with known boundaries (enter inventory no.) 92-00349

Relationship:  Contributing  Noncontributing

Contributes to a potential district with yet unknown boundaries

National Register Status:(any that apply)  Listed  De-listed  NHL  DOE

9-Digit SHPO Review & Compliance (R&C) Number \_\_\_\_\_

Non-Extant (enter year) \_\_\_\_\_

## 1. Name of Property

historic name Peterson & Flickinger Veterinarian Office

other names/site number Downtown Survey Map # DT- 106

## 2. Location

street & number 105 East Third St.

city or town Washington

vicinity, county Washingt

Legal Description: (If Rural) Township Name \_\_\_\_\_ Township No. \_\_\_\_\_ Range No. \_\_\_\_\_ Section \_\_\_\_\_ Quarter of Quarter \_\_\_\_\_

(If Urban) Subdivision 04 02 OP N 1/2 LOT 3 & N 1/2 E 10 FT

## 3. State/Federal Agency Certification [Skip this Section]

## 4. National Park Service Certification [Skip this Section]

## 5. Classification

Category of Property (Check only one box)

- building(s)
- district
- site
- structure
- object

### Number of Resources within Property

If Non-Eligible Property  
Enter number of:

If Eligible Property, enter number of:  
Contributing      Noncontributing

—	buildings	<u>1</u>	—	buildings
—	sites	—	—	sites
—	structures	—	—	structures
—	objects	—	—	objects
—	Total	<u>1</u>	—	Total

Name of related project report or multiple property study (Enter "N/A" if the property is not part of a multiple property examination).

Title \_\_\_\_\_

Historical Architectural Data Base Number \_\_\_\_\_

## 6. Function or Use

Historic Functions (Enter categories from instructions)

Current Functions (Enter categories from instructions)

99 Other - Veterinarian Office

02E08 Barber

## 7. Description

Architectural Classification (Enter categories from instructions)

Materials (Enter categories from instructions)

09: Commercial / tile block

foundation 10B Poured Concrete

walls (visible material) 16 tile block

roof 08B Rolled Asphalt

other \_\_\_\_\_

Narrative Description ( SEE CONTINUATION SHEETS, WHICH MUST BE COMPLETED)

## 8. Statement of Significance

Applicable National Register Criteria (Mark "x" representing your opinion of eligibility after applying relevant National Register criteria)

- Yes  No  More Research Recommended
- Yes  No  More Research Recommended
- Yes  No  More Research Recommended
- Yes  No  More Research Recommended

- A Property is associated with significant events.
- B Property is associated with the lives of significant persons.
- C Property has distinctive architectural characteristics.
- D Property yields significant information in archeology or history.

County Washington Address 105 East Third St.  
City Washington

Site Number 92-00588  
District Number 92-00349

**Criteria Considerations**

- A Owned by a religious institution or used for religious purposes.
- B Removed from its original location.
- C A birthplace or grave.
- D A cemetery
- E A reconstructed building, object, or structure.
- F A commemorative property.
- G Less than 50 years of age or achieved significance within the past 50 years.

**Areas of Significance** (Enter categories from instructions)

05: Commerce  
02: Architecture

**Significant Dates**

Construction date 1946  check if circa or estimated date  
Other dates, including renovation \_\_\_\_\_

**Significant Person**

(Complete if National Register Criterion B is marked above)

**Architect/Builder**

Architect \_\_\_\_\_

Builder \_\_\_\_\_

**Narrative Statement of Significance**  SEE CONTINUATION SHEETS, WHICH MUST BE COMPLETED

**9. Major Bibliographical References**

Bibliography  See continuation sheet for citations of the books, articles, and other sources used in preparing this form

**10. Geographic Data**

**UTM References (OPTIONAL)**

Zone	Easting	Northing	Zone	Easting	Northing
1	_____	_____	2	_____	_____
3	_____	_____	4	_____	_____

See continuation sheet for additional UTM references or comments

**11. Form Prepared By**

name/title Michael Kramme & Carol Ray, commission members Rebecca L. McCarley, consultant, Davenport  
organization Washington Historic Preservation Commission date April 6, 2012  
street & number City Hall – 215 E. Washington St telephone 319-653-6584  
city or town Washington state Iowa zip code 52353

**ADDITIONAL DOCUMENTATION (Submit the following items with the completed form)**

**FOR ALL PROPERTIES**

- Map:** showing the property's location in a town/city or township.
- Site plan:** showing position of buildings and structures on the site in relation to public road(s).
- Photographs:** representative black and white photos. If the photos are taken as part of a survey for which the Society is to be curator of the negatives or color slides, a photo/catalog sheet needs to be included with the negatives/slides and the following needs to be provided below on this particular inventory site:

Roll/slide sheet #	_____	Frame/slot #	_____	Date Taken	_____
Roll/slide sheet #	_____	Frame/slot #	_____	Date Taken	_____
Roll/slide sheet #	_____	Frame/slot #	_____	Date Taken	_____

- See continuation sheet or attached *photo & slide catalog sheet* for list of photo roll or slide entries.
- Photos/illustrations without negatives are also in this site inventory file.

**FOR CERTAIN KINDS OF PROPERTIES, INCLUDE THE FOLLOWING AS WELL**

- Farmstead & District:** (List of structures and buildings, known or estimated year built, and contributing or noncontributing status)
- Barn:**
  - A sketch of the frame/truss configuration in the form of drawing a typical middle bent of the barn.
  - A photograph of the loft showing the frame configuration along one side.
  - A sketch floor plan of the interior space arrangements along with the barn's exterior dimensions in feet.

**State Historic Preservation Office (SHPO) Use Only Below This Line**

Concur with above survey opinion on National Register eligibility:  Yes  No  More Research Recommended  
 This is a locally designated property or part of a locally designated district.

Comments: \_\_\_\_\_

Evaluated by (name/title): \_\_\_\_\_ Date: \_\_\_\_\_

# Iowa Site Inventory Form Continuation Sheet

Page 1

---

<u>Peterson &amp; Flickinger Veterinarian Office</u>	<u>Washington</u>
Name of Property	County
<u>105 E. Third St.</u>	<u>Washington</u>
Address	City

---

*This form was prepared as part of a research/survey/nomination project in 2011-2012 funded by a HRDP grant from the State Historical Society of Iowa for the nomination of the Washington Downtown Historic District. The project was primarily structured to develop the nomination for the downtown, with additional research on each building documented on an Iowa Site Inventory form. The information below is taken from the table in the August 2012 draft of the nomination, with additional information documented on the property and photographs in the following sections.*

**Peterson & Flickinger Veterinarian Office - 105 E. Third St** - State #92-00588 - Map #37 ~ 1 contributing building (A and C) - 1946 - 1940s commercial modern

Historic information:

c.1946-c.1955 - Peterson and Flickinger - veterinarians

1956-1960s - Peterson, Flickinger and Larsen Veterinarian Office

1983 - Flickinger & Minneman, 1984 - Washington Town & Country Veterinarian Clinic, 2000 - Chorpening Real Estate, 2002-2010s - Krantz Barber Shop

2012 - Krantz Barber Shop

Architectural information:

Height: 1 story

Walls: block

Storefront: -

Windows: -

Architectural details: tile block construction

Architect/Builder: -

Modifications: -

## 7. Narrative Description

The building is a small, one-story, tile block building. The west end appears built separately from the east end, though perhaps near the same time as the materials and details closely match. The primary facade contains the entry in the center and a double vertical window on each side. The east side contains two double vertical windows in the north half, then a small double-hung window and a large glass block window to the south. The west side has a double vertical window and a similar opening filled with panels and small windows.

## 8. Narrative Statement of Significance

The Peterson & Flickinger Veterinarian Office appears to contribute historically and architecturally to the Washington Downtown Historic District.

The assessor lists 1946 as the construction date. The first record of this building's use is the Peterson & Flickinger Veterinarian Office in the 1947 phone directory. In 1956 the business was Peterson, Flickinger and Larsen. By 1983 it was Flickinger & Minneman. In 1984, it was home to the Washington

# Iowa Site Inventory Form Continuation Sheet

Page 2

---

<u>Peterson &amp; Flickinger Veterinarian Office</u>	<u>Washington</u>
Name of Property	County
<u>105 E. Third St.</u>	<u>Washington</u>
Address	City

---

Town & Country Veterinarian Clinic. In 2000 Chorpening Real Estate office used the building, and in 2002 it became the Krantz Barber Shop. In addition to the barber shop, the Complete Computer Center shared the space from 2003 to 2008.

## 9. Major Bibliographical References

City/Telephone Directories, Washington. Various publishers, various dates. Available at the Washington Public Library.

Deed Records, Transfer Books, Auditor's Office, Washington County Courthouse, Washington, Iowa.

Newspaper advertisements, various years/dates, on microfilm at Washington Public Library:

- Washington Evening Journal*
- Washington Gazette*
- Washington Press*

Sanborn Map Company. "Washington, Iowa," Sanborn fire insurance maps. Pelham, NY: Sanborn Map Company, 1885, 1892, 1897, 1902, 1909, 1917, 1931, 1943.

Iowa Department of Cultural Affairs  
State Historical Society of Iowa  
**Iowa Site Inventory Form**  
**Continuation Sheet**

Site Number 92-00588  
Related District Number 92-00349

Page 3

Peterson & Flickinger Veterinarian Office	Washington
Name of Property	County
105 E. Third St.	Washington
Address	City

**Location map**



*2009 aerial photograph (Washington County) – line indicates survey/research area boundary*

# Iowa Site Inventory Form Continuation Sheet

Page 4

---

<u>Peterson &amp; Flickinger Veterinarian Office</u>	<u>Washington</u>
Name of Property	County
<u>105 E. Third St.</u>	<u>Washington</u>
Address	City

---

### Building plan (from assessor's website)

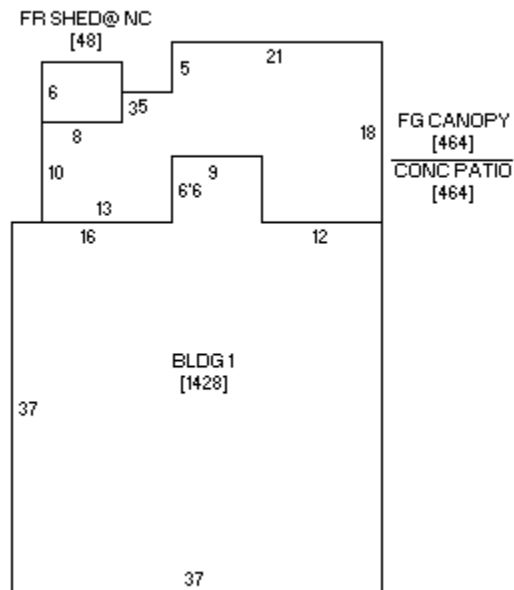

### Historic images

none identified

# Iowa Site Inventory Form Continuation Sheet

Page 5

Peterson & Flickinger Veterinarian Office

Washington

Name of Property

County

105 E. Third St.

Washington

Address

City

## Digital photographs



92-00588-001 - North and west elevations, looking southeast (McCarley, September 20, 2011)

# Iowa Site Inventory Form Continuation Sheet

Page 6

Peterson & Flickinger Veterinarian Office

Washington

Name of Property

County

105 E. Third St.

Washington

Address

City



92-00588-002 - East and north elevations, looking southwest (McCarley, September 20, 2011)